

DUAL-LINE 6-DIGIT PROCESS METER

PROVU
SERIES

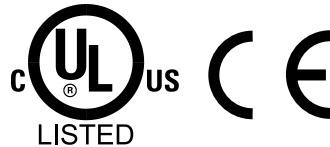

ProVu • Model PD6000

- 0-20 mA, 4-20 mA, 0-5 V, 1-5 V, and ± 10 V Inputs
- NEMA 4X, IP65 Front
- Universal 85-265 VAC or 12/24 VDC Input Power
- Large Dual-Line 6-Digit Display, 0.6" & 0.46"
- Isolated 24 VDC @ 200 mA Transmitter Power Supply
- Math Functions for Flow & Round Horizontal Tanks
- Programmable Displays & Function Keys
- Sunlight Readable Display
- 32-Point, Square Root, or Exponential Linearization
- Multi-Pump Alternation Control
- 2 or 4 Relays + Isolated 4-20 mA Output Options
- External 4-Relay & Digital I/O Expansion Modules
- RS-232, RS-422/485 Serial Communication Options
- -40 to 65°C Operating Temperature Range

PRECISION DIGITAL CORPORATION

PRECISION
DIGITAL

www.predig.com

Large
0.6" Digits

6-Digit
Dual-Line
Display

Rugged Front

User Configurable
Display



(Actual Size)

Sunlight
Readable

PV, Max/Peak,
Min/Valley

Programmable
Function Keys

NEMA 4X

Status Indicators

FEATURE RICH AND FLEXIBLE

The ProVu meter boasts specifications and functionality that clearly makes it one of the most advanced process meters available. Its dual-line 6-digit display (999,999), advanced math functions, function keys, and optional expansion modules are only a few of the features you will find on the ProVu.

FRONT PANEL DISPLAY

Precise, Accurate, and More Informative

ProVu's large 0.6" main display will provide you with a highly accurate and precise six-digit view of your process. Its 24-bit A/D is accurate to 0.03% FS ±1 count.



Configurable

The main display can be programmed to indicate PV, maximum (peak), minimum (valley), alternating maximum/minimum, or one of eight alarm set points. The secondary display can also be configured to display engineering units, user defined legends, or simply turned off.

Function Keys

There are three function keys available to the user. These keys can be programmed to trigger certain events (i.e. acknowledge alarms, reset max and/or min, disable/enable output relays, or hold current relay states), provide direct menu access points, and more.



Environmentally Tough

UV Resistant
Sunlight Readable

NEMA 4X Rated



Rugged

A unique front panel design makes the ProVu nearly impenetrable in typical applications. Here, the ProVu easily survives a direct hit on the display from a heavy 2" solid stainless steel ball dropped from eight feet.



Easy to Use

The user friendly dual-line display makes the ProVu easy to set up & program. No jumpers to set, or potentiometers to adjust. All setup & programming is done via the front panel. Three levels of password protection help maintain the reliability of the programming.



FIELD EXPANDABLE OPTIONS

Add functionality to the **ProVu** in the field with easy-to-install external expansion modules. Add RS-232 or RS-422/485 communications, I/O modules (2), or 4-relay expansion module. The menu items for these modules do not appear until the module is installed, simplifying the basic menu. Shown here with optional DIN rail mounting kit, P/N PDA1002.



I/O Expansion Module

Four digital inputs and four digital outputs are available per expansion module. The **ProVu** meter will accept two of these modules. External digital inputs can function similarly to the front panel function keys. They can be configured to trigger certain events (i.e. acknowledge/reset alarms, reset max and/or min values, disable/enable all output relays, and hold current relay states), provide direct menu access point, or mimic front panel keys.

Digital outputs can be used to remotely monitor **ProVu's** alarm relay output states, or the states of a variety of actions and functions executed by the meter.

Relay Expansion Module

An external module containing four 3 amp Form A (SPST) relays can be added to the **ProVu** at anytime. Removable screw terminal blocks accept 12 to 22 AWG wire.



Communications Module

Serial communications on the **ProVu** can be added anytime with external RS-232 or RS-422/485 communication adapters.



MULTI-PUMP ALTERNATION

Up to 8 pumps can be alternated/sequenced.

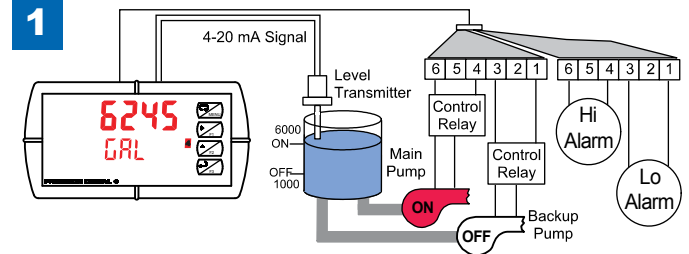

Relay #4 turns the main pump on at 6000 gallons and turns it off at 1000 gallons.

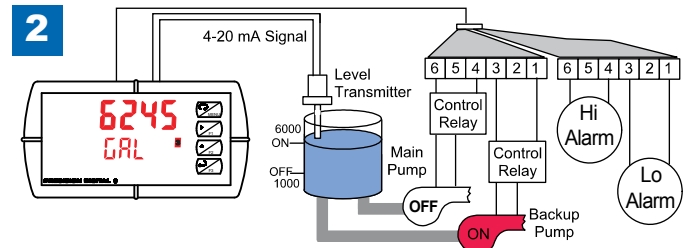

With the Pump Alternation feature activated, the next time the level reaches 6000 gallons, relay #3 transfers and starts the backup pump.

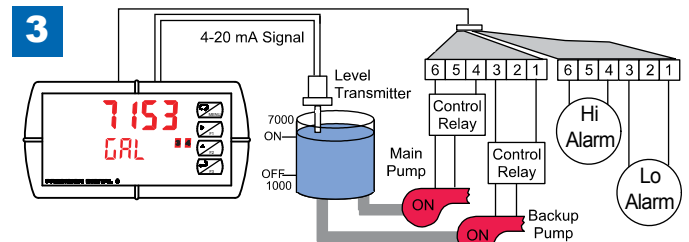

If the backup pump is not able to keep up, and the level reaches 7000 gallons, relay #4 transfers and starts the main pump as well.

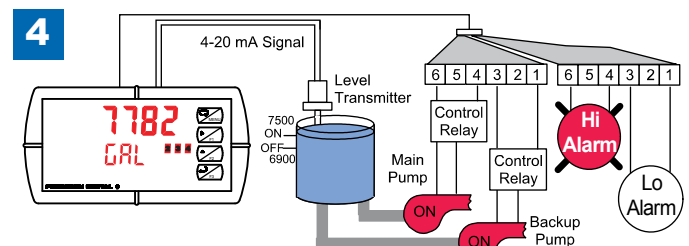

Relay #2 trips the High Level Alarm at 7500 gallons and resets at 6900 gallons.

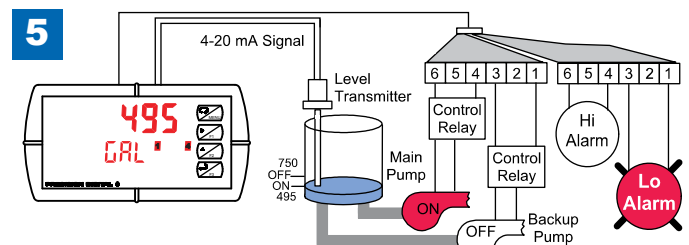

Relay #1 trips the Low Level Alarm at 495 gallons and resets at 750 gallons.

MATH FUNCTIONS

Non-linear input signals can be linearized with our simple to use built-in math functions, such as: square-root extractor, weirs & flumes exponential linearizer, horizontal round tank linearizer, or our powerful general purpose 32-point linearizer (free linearization utility available at www.predig.com).

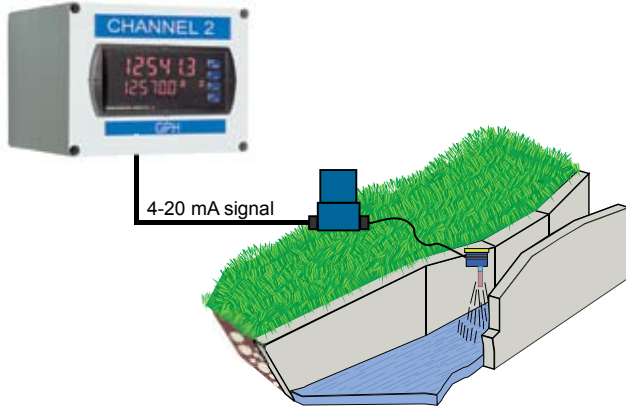

Weirs and Flumes Math Function

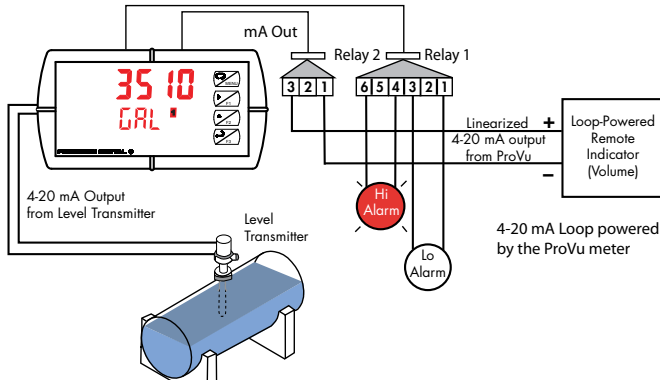

Round Horizontal Tank Math Function

METER COPY

The Copy feature is used to copy (or clone) all the settings from one ProVu to other ProVu meters in about 20 seconds! The Copy function is a standard feature on all meters. It does not require a communications adapter, only an optional cable assembly, P/N PDA1200. See the ordering information for complete details.



OUTPUTS

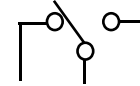

Relay Outputs

The ProVu has up to four 3 A Form C relays (SPDT), giving you more fail-safe options upon power loss. Relay action can also be configured for input loop break protection. Set ON and OFF delay times when needed. Up to eight front panel indicators show alarm and/or relay state. Can be configured for 0-100% deadband.

Relay Operation/Configuration

There are powerful relay functions that can be configured in the ProVu meter, including:

- Automatic reset only (non-latching)
- Automatic + manual reset at any time (non-latching)
- Latching (manual reset only)
- Latching with Clear (manual reset only after alarm condition has cleared)
- Pump alternation control (automatic reset only)
- Sampling (activated for a user-specified time)
- User selectable fail-safe operation
- Relay action for loss (break) of 4-20 mA input signal
- Time delay (on and off), independent for each relay

Analog Output

The isolated analog retransmission signal can be configured to represent the process variable (PV), maximum (peak) value, minimum (valley) value, or the value for any of the eight relay set points. While the output is nominally 4-20 mA, the signal will accurately accommodate under- and over-ranges from 1 to 23 mA.

Auto/Manual Control

Take control of any output with this feature. All relays can be forced ON or OFF, and the 4-20 mA output signal can be set to any value within its range.

Isolated Transmitter Power Supplies

A powerful 24 V @ 200 mA power supply is a standard feature on the ProVu meter. It can be configured for 5, 10, or 24 V (default) by means of a simple internal jumper (see manual). An additional power supply (24 V @ 40 mA) is standard with the 4-20 mA output option.

NEMA 4 & 4X FIELD ENCLOSURES

Plastic, stainless steel, and painted steel NEMA 4 enclosures for up to 10 ProVu meters.



See our complete offering at www.predig.com/ProVu

CONNECTIONS

- Form C (SPDT) relays
- Two isolated supplies available even on 12/24 VDC input power models
- Removable terminal blocks
- 2 or 4 relays + isolated 4-20 mA output option

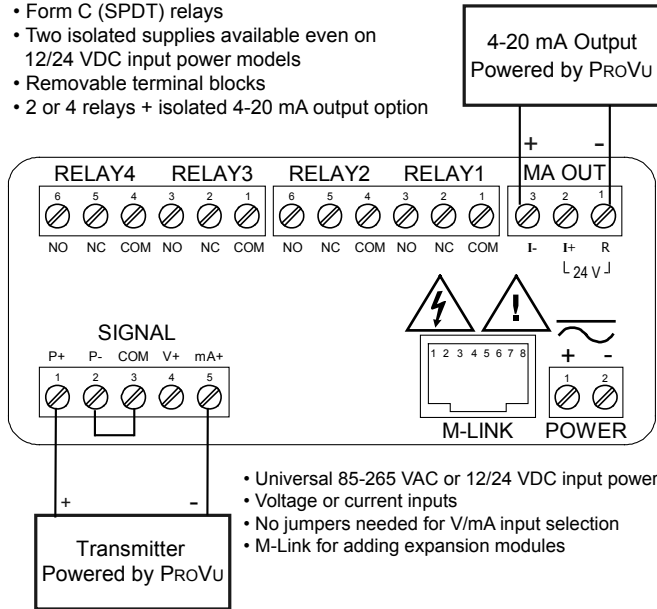

- Universal 85-265 VAC or 12/24 VDC input power
- Voltage or current inputs
- No jumpers needed for V/mA input selection
- M-Link for adding expansion modules

SPECIFICATIONS

Except where noted all specifications apply to operation at +25°C.

General

Display: Main display: 0.6" (15 mm) high, red LED. Second display: 0.46" (12 mm) high, red LED 6 digits (-99999 to 999999), lead zero blanking.

Display Intensity: Eight intensity levels

Display Update Rate: 5/second (200 ms)

Overrange: Display flashes 999999

Underrange: Display flashes -99999

Front Panel: NEMA 4X, IP65

Programming Methods: Four front panel buttons, PC based linearization utility, cloning using Copy function, or via digital inputs.

Noise filter: Programmable from 2 to 199 (0 will disable filter)

Filter Bypass: Programmable from 0.1 to 99.9% FS

Recalibration: Calibrated at the factory. Recalibration is recommended at least every 12 months.

Max/Min Display: Max (Peak)/min (Valley) readings reached by the process are stored until reset by the user or until power to the meter is turned off.

Password: Three programmable passwords restrict modification of programmed settings. Pass 1: Allows use of the F1–F3 function keys. Pass 2: Allows use of the F1–F3 function keys and changing the set/reset points. Pass 3: Restricts all programming and F1–F3 keys. *Note: Digital inputs are not password protected.*

Non-Volatile Memory: All programmed settings are stored in non-volatile memory for a minimum of ten years if power is lost.

Power Options: 85-265 VAC 50/60 Hz, 90-265 VDC 20 W max or 12/24 VDC ±10% (jumper selectable), 15 W max.

Fuse: Required external fuse: UL Recognized, 5 A max, slow blow; up to 6 meters may share one 5 A fuse.

Isolated Transmitter Power Supply: 5, 10, or 24 VDC selectable by internal jumper. 24 VDC ± 5% supply rated @ 200 mA max (100 mA max for 12/24 VDC powered models). The 5 or 10 VDC supplies rated @ 50 mA max.

Normal Mode Rejection: Greater than 60 dB at 50/60 Hz

Isolation: 4 kV input/output-to-power line. 500 V input-to-output or output-to-P+ supply.

Environmental: Operating temperature range: -40 to 65°C. Storage temperature range: -40 to 85°C. Relative humidity: 0 to 90% non-condensing.

Connections: Removable screw terminal blocks accept 12 to 22 AWG wire, RJ45 for external relays, digital I/O, and serial communication adapters.

Enclosure: 1/8 DIN, high impact plastic, UL 94V-0, color: black

Mounting: 1/8 DIN panel cutout required: 3.622" x 1.772"

(92 mm x 45 mm). Two panel mounting bracket assemblies are provided.

Tightening Torque: Screw terminal connectors: 5 lb-in (0.56 Nm)

Overall Dimensions: 4.68" x 2.45" x 5.64"

(119 mm x 62 mm x 143 mm) (W x H x D)

Weight: 9.5 oz (269 g)

UL File Number: UL & c-UL Listed. E160849; 508 Industrial Control Equipment.

Warranty: 3 years parts & labor

Process Input

Inputs: Field selectable: 0-20, 4-20 mA, ±10 VDC (0-5, 1-5, 0-10 V)

Accuracy: ±0.03% FS ±1 count, square root & programmable exponent accuracy range: 10-100% FS

Temperature Drift: From 0 to 65°C ambient: 50 PPM/°C.

From -40 to 0°C ambient: 100 PPM/°C.

Math Function: Linear, square root, programmable exponent, or round horizontal tank volume calculation.

Multi-Point Linearization: 2 to 32 points

Programmable exponent: 1.0001 to 2.9999

Low-Flow Cutoff: 0-999999 (0 disables cutoff function)

Decimal Point: Up to five decimal places or none: d.ddddd, dd.dddd, ddd.ddd, dddd.dd, ddddd.d, or ddddd.

Calibration Range: Minimum span: 0.15 mA or 0.10 V. An Error message will appear if input 1 and input 2 signals are too close together.

Input Impedance: Voltage ranges: greater than 1 MΩ. Current ranges: 50 - 100 Ω (depending on resettable fuse impedance).

Input Overload: Current input protected by resettable fuse, 30 VDC max. Fuse resets automatically after fault is removed.

Relays

Rating: 2 or 4 SPDT (Form C) internal and/or 4 SPST (Form A) external; rated 3 A @ 30 VDC and 125/250 VAC resistive load; 1/14 HP @ 125/250 VAC for inductive loads

Noise Suppression: Noise suppression is recommended for each relay contact switching inductive loads.

Deadband: 0-100% FS, user programmable

High or Low Alarm: User may program any alarm for high or low trip point. Unused alarm LEDs and relays may be disabled (turned off).

Relay Operation: automatic (non-latching), latching (requires manual acknowledge), sampling (based on time), and pump alternation control (2 to 8 relays).

Relay Reset: User selectable via front panel buttons or digital inputs.

1. Automatic reset only (non-latching), when input passes the reset point.
2. Automatic + manual reset at any time (non-latching).
3. Manual reset only, at any time (latching).
4. Manual reset only after alarm condition has cleared (latching).

Note: Front panel button or digital input may be assigned to acknowledge relays programmed for manual reset.

Time Delay: 0 to 999.9 seconds, on & off relay time delays. Programmable and independent for each relay.

Fail-Safe Operation: Programmable and independent for each relay. *Note: Relay coil is energized in non-alarm condition. In case of power failure, relay will go to alarm state.*

Auto Initialization: When power is applied to the meter, relays will reflect the state of the input to the meter.

Isolated 4-20 mA Transmitter Output

Output Source: Process variable (PV), max, min, or set points 1-8

Scaling Range: 1.000 to 23.000 mA for any display range

Calibration: Factory calibrated: 4.000 to 20.000 = 4-20 mA output

Accuracy: ± 0.1% FS ± 0.004 mA

Temperature Drift: 50 PPM/°C from 0 to 65°C ambient

Note: Analog output drift is separate from input drift.

Isolated Transmitter Power Supply: Terminals I+ & R: 24 VDC ± 5% @ 40 mA maximum, may be used to power the 4-20 mA output or other devices. Present on both AC & DC powered units.

External Loop Power Supply: 35 VDC maximum

Output Loop Resistance:

Power supply	Minimum	Maximum
24 VDC	10 Ω	700 Ω
35 VDC (external)	100 Ω	1200 Ω

Serial Communications

Meter Address: 1 - 247

Baud Rate: 300 - 19,200 bps

Transmit Time Delay: Programmable between 0 and 199 ms or transmitter always on for RS-422 communication

Data: 8 bit (1 start bit, 1 stop bit)

Parity: None

Turn Around Delay: Less than 2 ms (fixed)

Digital I/O Expansion Module

Channels: 4 digital inputs & 4 digital outputs per module

System: Up to 2 modules for a total of 8 inputs & 8 outputs

Digital Input Logic: High: 3 to 5 VDC **Low:** 0 to 1.25 VDC

Digital Output Logic: High: 4.75 to 5 VDC **Low:** 0 to 0.4 VDC

Source Current: 10 mA maximum

Sink Current: 1.5 mA minimum

+5 V Terminal: To be used as pull-up for digital inputs only.

4-Relay Expansion Module

Relays: Four Form A (SPST) rated 3 A @ 30 VDC and 125/250 VAC resistive load; 1/4 HP @ 125/250 VAC for inductive loads.

MOUNTING DIMENSIONS

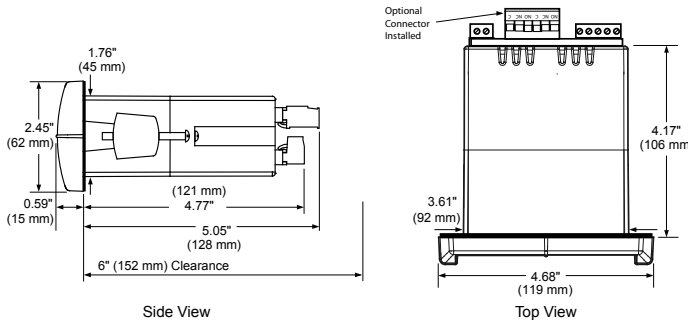

Notes:

1. Panel cutout required: 1.772" x 3.622" (45mm x 92mm)
2. Panel thickness: 0.040 - 0.250" (1.0mm - 6.4mm)
3. Mounting brackets lock in place for easy mounting
4. Clearance: Allow 6" (152 mm) behind the panel

ORDERING INFORMATION

ProVu • Model PD6000		
85-265 VAC Model	12/24 VDC Model	Options Installed
PD6000-6R0	PD6000-7R0	None
PD6000-6R2	PD6000-7R2	2 Relays (PD1102*)
PD6000-6R3	PD6000-7R3	4-20 mA Output (PD1103*)
PD6000-6R4	PD6000-7R4	4 Relays (PD1104*)
PD6000-6R5	PD6000-7R5	2 Relays & 4-20 mA Out (PD1105*)
PD6000-6R7	PD6000-7R7	4 Relays & 4-20 mA Out (PD1107*)

Note: 24 V Transmitter power supply standard on all models.
* Model number for replacement option board or field-installed options.

Accessories	
Model	Description
PDA1002	DIN Rail Mounting Kit for Two Expansion Modules
PDA1004	4-Relay Expansion Module
PDA1044	4 Digital Inputs & 4 Digital Outputs Module
PDA1200	Meter Copy Cable
PDA1232	RS-232 Serial Adapter
PDA1485	RS-422/485 Serial Adapter
PDA7485-I	RS-232 to RS-422/485 Isolated Converter
PDA7485-N	RS-232 to RS-422/485 Non-Isolated Converter
PDA8232-N	USB to RS-232 Non-Isolated Converter
PDA8485-I	USB to RS-422/485 Isolated Converter
PDA8485-N	USB to RS-422/485 Non-Isolated Converter
PDX6901	Suppressor (snubber): 0.01 μF/470 Ω, 250 VAC



Disclaimer

The information contained in this document is subject to change without notice. Precision Digital Corporation makes no representations or warranties with respect to the contents hereof, and specifically disclaims any implied warranties of merchantability or fitness for a particular purpose. ©2008 Precision Digital Corporation. All rights reserved.

Your Local Distributor is: