

Features

- Low cost, high performance, suitable for batch application
- 50Hz refresh rate, 10Hz response frequency
- $\pm 0.07^\circ$ accuracy@-15~50°C
- $\pm 0.2\%$ cross-axis error
- Available to horizontal, vertical, headstand, etc installation methods
- IP67 protection
- 9~36VDC power supply
- Sensing elements survive to 1500g shock while operating



Applications

Vessel, Engineering machinery, Solar/wind energy, automobile/truck/vehicle, Communication/electric Tower monitoring, High-voltage pylon monitoring, Antenna, construction engineering, Landslide, etc

Descriptions

SST20 inclinometer based on Vigor's advanced tilt measurement technology, to meet with low cost, high reliability and volume application, performs high performance-cost ratio.

SST20 employed most universal & mass-produced components, casting aluminum alloy house, universal high reliability M12-5pin industrial connector; IP67 protection, auto-test/calibration equipment which not only ensure delivery speed, also keep the consistency of goods

Thanks for Vigor engineers, they adopt advanced technologies as:

- CAE/EDA simulation;
- Modal test for both housing and PCB to eliminate resonance due to vibration;
- Comprehensive performance & function test for component & firmware;
- Calibration technology based on SST300 high accuracy inclinometer;
- Refer MIL/ EN/ ISO/IEC standards to enhance SST20 durability & reliability.

MTBF more than 10 years per time and has better EMC ability.

SST20 output RS232/RS485/CAN/CANOpen/Switch and Voltage/Current signals. Better power management to meet with automotive /truck/vehicle application without regulated power.

OEM service is available with calibrated PCBA or MIL qualified.

Performances (@25°C test conditions, except other notifications)

Output Interface	RS232/RS485/CAN/CANOpen/Switch	0.5~4.5VDC/4~20mA
Measurement range	$\pm 5^\circ$, $\pm 10^\circ$, $\pm 15^\circ$, $\pm 30^\circ$, $\pm 45^\circ$, $\pm 60^\circ$, $\pm 90^\circ$, $\pm 180^\circ$, 0~360°	
Accuracy	$\pm 0.07^\circ @ -15 \sim 50^\circ\text{C}$	$\pm 0.15^\circ @ -15 \sim 50^\circ\text{C}$
Non-linearity	$\pm 0.03^\circ$	$\pm 0.05^\circ$
Resolution	0.002°	0.005°
Repeatability	$\pm 0.02^\circ$	$\pm 0.05^\circ$
Offset	$\pm 0.02^\circ$	$\pm 0.05^\circ$
Cross-axis sensitivity	$\pm 0.2\%$ FS	$\pm 0.2\%$ FS
Measuring axis	1 or 2 axis ($\pm 180^\circ$ and 0~360° measurement range single axis only)	
Bandwidth	Default 3Hz, 5Hz, 10Hz available	
Response time	5ms (no filtering)	10ms (no filtering)
Refresh rate	Default 5Hz, max. 50Hz	50Hz
Cold start warming time	Less than 60s	
Interface features	RS232: 9600bps (adjustable), 8 data bits, 1 start bit, 1 stop bit	Voltage output: 0.5~4.5VDC; Internal resistance 0.3Ω; Drive current (max.) 15mA
	RS485: 9600bps (adjustable), 8 data bits, 1 start bit, 1 stop bit No matched resistance	
	CAN2.0: according to ISO11898-2 standard, 40k~1MBit/s baud rate, adaptive standard frame and extended frame format No matched resistance	
	CANOpen: according to DS301 standard, 40k~1MBit/s baud rate No matched resistance	Current output: 4~20mA; Internal resistance 50MΩ; load impedance 150~650Ω
	Switch output: Darlington OC output, load with 1A @ 9~36VDC, alarm point can be pre-set in factory	
Power consumption	RS232/RS485 Output: 9~36VDC, current $\leq 50\text{mA} @ 24\text{VDC}$	9~36VDC current $\leq 30\text{mA}$ (no-load) @ 24VDC
	CAN/CANOpen Output: 9~36VDC, current $\leq 80\text{mA} @ 24\text{VDC}$	
	Switch output: 9~36VDC, current $\leq 50\text{mA}$ (no-load) @ 24VDC	
Operation temperature range	-40 ~ 85°C	
Storage temperature range	-40 ~ 85°C	
EMC	According to EN 61000/GBT17626	
Insulation	$\geq 100\text{M}\Omega$	
MTBF	10 years	
Shock	100g@11ms, three-axis, half-sine	
Vibration	8grms, 20~2000Hz	
Protection	IP67	
Connector	M12 5-Pin socket	
Weight	$\leq 200\text{g}$ (no connector or cable)	

Demisions (mm)

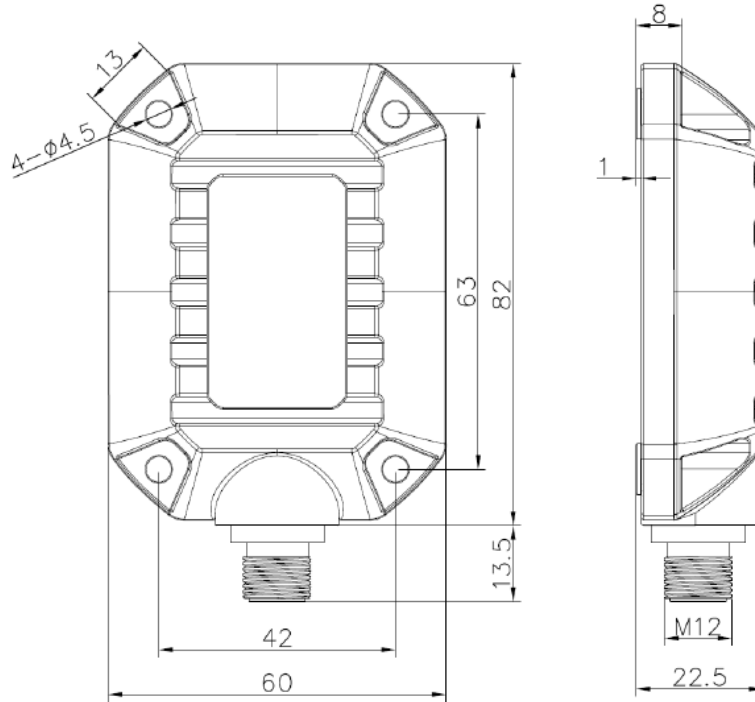

Wiring

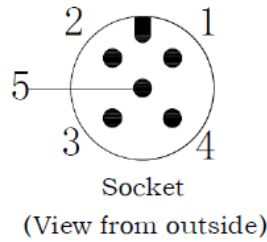
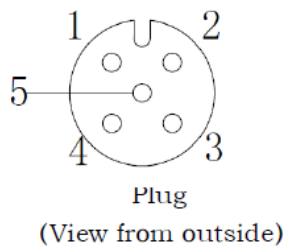

Pin	Wire color	Output interface						
		RS232	RS485	CAN	CANOpen	voltage	Current	Switch alarm
1	Red	Power+	Power+	Power+	Power+	Power+	Power+	Power+
2	Black	Power GND	Power GND	Power GND	Power GND	Power/Signal GND	Power/Signal GND	Power/Signal GND
3	Blue	TXD	RS485-A	CAN_H	CAN_H	Vx	Ix	Control power +
4	Brown	RXD	RS485-B	CAN_L	CAN_L	Vy	Iy	X axis Alarm
5	Green	Signal GND	Signal GND	Signal GND	Signal GND	External zero set	External zero set	Y axis Alarm

Remarks: if order switch alarm output inclinometer, only provide factory settings for alarm point. If you need set alarm point with special request, should specify all requirements when ordering. Single axis inclinometer only has X axis.

Ordering

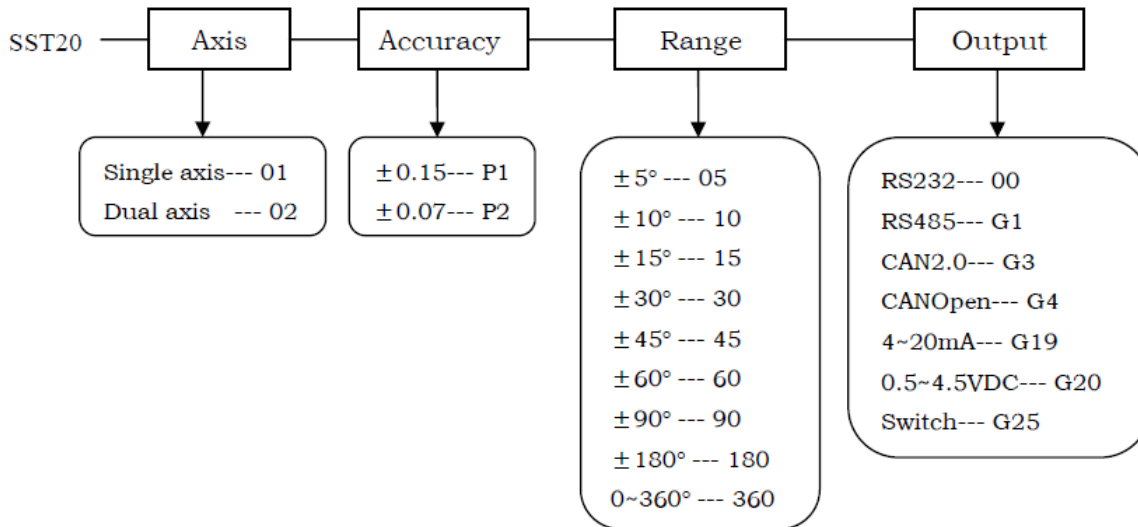

Remarks: 4~20mA and 0.5~4.5VDC output inclinometer only provide 0.15° accuracy class; RS232/485, CAN2.0, CANOpen and switch output inclinometer only provide 0.07 accuracy class.

For example: if order a dual-axis SST20 inclinometer, range $\pm 30^\circ$, $\pm 0.07^\circ$ accuracy, output CAN2.0, the model should be chosen as :SST20-02-P2-30-G3